

70TV Tandem Axle Vanguard

G.V.W.R.	7,000#	AXLES	Two 3,500# EZ Lube w/1 Elec. Brake
G.A.W.R. (Ea. Axle)	3,500#	SUSPENSION	Multi-Leaf Spring
COUPLER	7K 2" Forged Coupler	TIRE	ST205/75-15 Load Range C
SAFETY CHAINS	1/4" Grd. 70 w/Safety Latch Hook (2 each)	WHEEL	15 x 5 White Spoke 5 Bolt
JACK	2,000# Top Wind (Bolted On)	FLOOR	2" Pine
TONGUE	4" Channel Fold Back Tongue	LIGHTS	D.O.T. Stop, Tail, Turn & Clearance
TOP RAIL	2-3/8" Pipe Top Rail	ELEC. PLUG	7-Way RV
FRAME	4" x 3" x 1/4" Angle	FINISH (Prep)	Steel is Cleaned to Ensure a Professional Smooth Finish.
CROSSMEMBERS	3" x 2" x 3/16" Angle	FINISH	Superior Quality Finish is Applied with Pin-Stripping for a Highly Decorative and Protective Finish.
UPRIGHTS	3" x 2" x 3/16" Angle		
FENDERS	9" x 72" Tear Drop		

Standard Features

- Forged Coupler
- Safety Chains Attached w/Cold Rolled Eyelets
- Sand Foot on Jack
- Set Back Jack
- Lower Jack Support Plate
- Fold Back Tongue (14' and longer)
- 83" Wide (Inside)
- 29-3/8" Sides w/24" V-Crimped Steel Panels & 2-1/2" Opening
- 2-3/8" Pipe Top Rail
- Floor Secured w/Torx Screws
- 4 Tie Down Loops Inside
- Cambered EZ Lube Axles
- Two 3,500# Axles w/1 Electric Brake
- Complete Break-A-Way System w/Charger
- Grommet Mount Sealed Lighting

Shown with Optional Rampgate

Dimensions			
Length	A	B	C
12'	145-1/2"	85"	60-1/2"
14'	169-1/2"	103"	66-1/2"
16'	193-1/2"	115"	78-1/2"

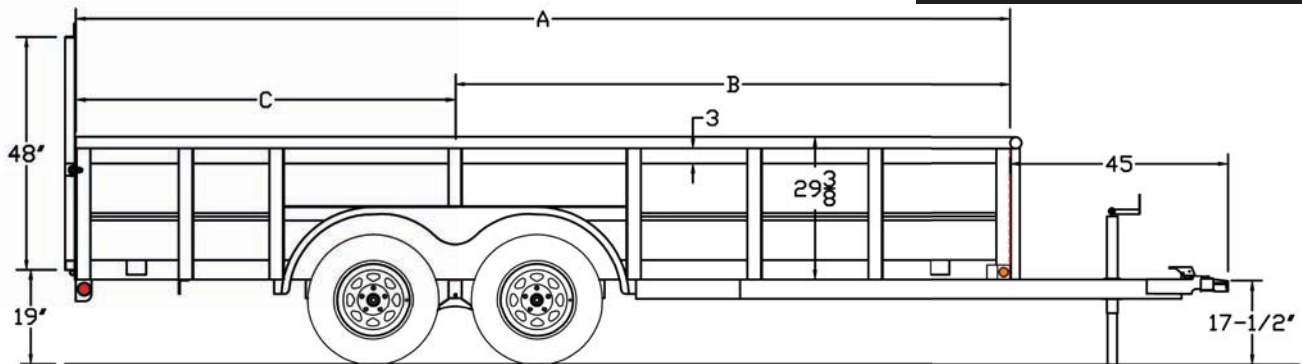

MODEL#	WEIGHT	DESCRIPTION
70TV-12	1,810#	83" x 12' Tandem Axle Vanguard
70TV-14	1,990#	83" x 14' Tandem Axle Vanguard
70TV-16	2,010#	83" x 16' Tandem Axle Vanguard

OPTIONS

2-5/16" Stamped Coupler	Spare Tire (ST205/75-15 LR-C)
2-5/16" Forged Coupler	Tire Upgrade (ST225/75-15 LR-D)
2K Fold-Up Jack	Spare Tire Upgrade (ST225/75-15 LR-D)
Electric Brakes on 2nd Axle	4' Rampgate (7 W)
Hydraulic Brakes 1 Axle w/Toledo Actuator	Gas Spring Assist Option - Rampgate
Hydraulic Brakes 2 Axles w/Toledo Actuator	Removable Landscape Box
Spare Tire Mount	Tool Holders (each)