

70SR Tandem Axle Single Ram Dump

G.V.W.R.	7,000#
G.A.W.R. (Ea. Axle)	3,500#
COUPLER	2-5/16" Stamped A-Frame
SAFETY CHAINS	1/4" Grd. 70 w/Safety Latch Hook (2 each)
JACKS	2,000" Top Wind (Bolted On)
TONGUE	5" Channel
FRAME	5" Channel
CROSSMEMBERS	6" Channel
BED CROSSMEMBERS	2" x 2" Square Tubing
BED SIDE RAILS	3" x 2" Tubing
FENDERS	9" x 72" Straight
AXLES	Two 3,500# EZ Lube w/Elec. Brakes
SUSPENSION	Multi-Leaf Spring w/Equalizer
TIRE	ST205/75-15 Load Range C
WHEEL	15 x 5 White Spoke 5 Bolt
FLOOR	16 Gauge Smooth Steel
LIGHTS	D.O.T. Stop, Tail, Turn & Clearance
ELEC. PLUG	7-Way RV
FINISH (Prep)	Steel is Cleaned and Etched to Ensure Smooth, High Bond Paint Adhesion.
FINISH	Painted with High-Solids Supreme Automotive Grade Enamel and Pin-Striped for a Highly Decorative and Protective Finish.

Standard Features

- Safety Chains Attached w/Cold Rolled Eyelets
- Enclosed Pump & Battery Box Mounted in Front of Bed
- Lockable Control Unit
- 20", 16 Ga. Sides w/Formed Channel Supports
- Tie Down Loops on All Four Sides
- Single Cylinder Lift
- 45 Degree Dump Angle
- Cambered EZ Lube Axles
- Complete Break-A-Way System w/Charge Line
- Grommet Mount Sealed Lighting
- 1 Piece 2 Way Style Rear Gate

Dimensions			
Length	A	B	C
10'	120"	55-1/2"	64-1/2"

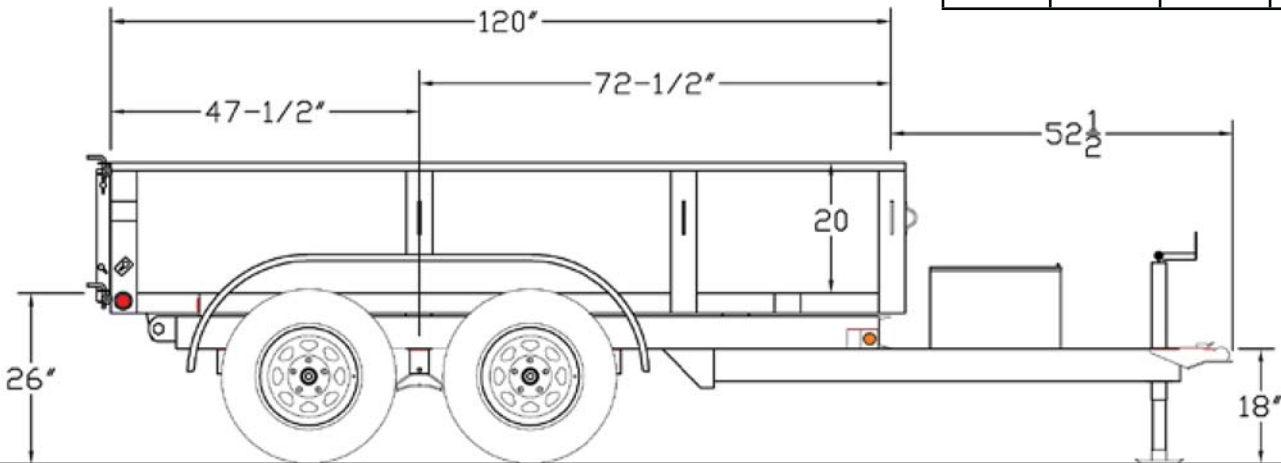

MODEL#	DESCRIPTION
70SR-10	72" x 10' Tandem Axle Single Ram Dump

TRAILER WEIGHTS & CAPACITIES

LENGTH	EMPTY WEIGHT	PAYLOAD	BOX CAPACITY
10'	2,000#	5,000#	2.5 Cubic Yards

OPTIONS

Spare Tire (ST205/75-15 LR-C)	5 Watt Solar Charger
Wireless Remote	110V Charger
2 Watt Solar Charger	Crank Style Roll Tarp